

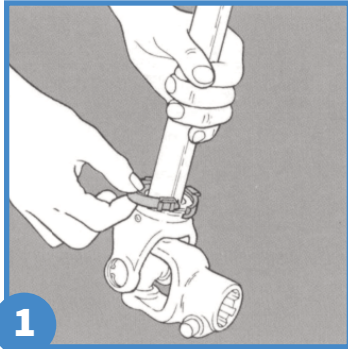

## Higher value. Smarter solutions.

### SERVICE INSTRUCTIONS



1 Clean and grease bushing groove before the bushing is placed in the groove. Grease any remaining bushings in guard.

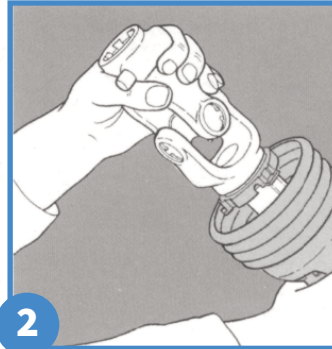

2 Slide guard half over drive shaft and insert bushing tabs into the openings in the guard.

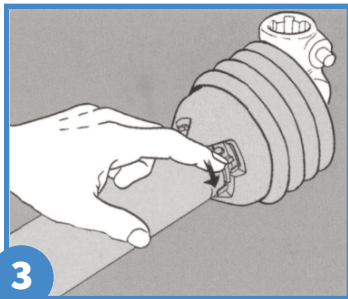

3 Turn the bushing until it engages into the guard.

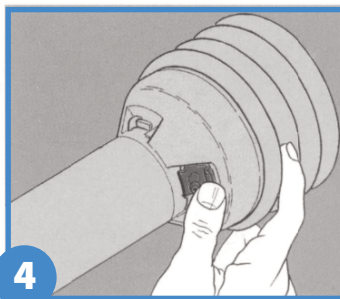

4 Push Easy Lock clip into position. The bushing and guard are now secure.

5 TO REMOVE GUARD - Use screwdriver to release Easy Lock clip. Turn the bushing to disengage from the guard and remove guard.

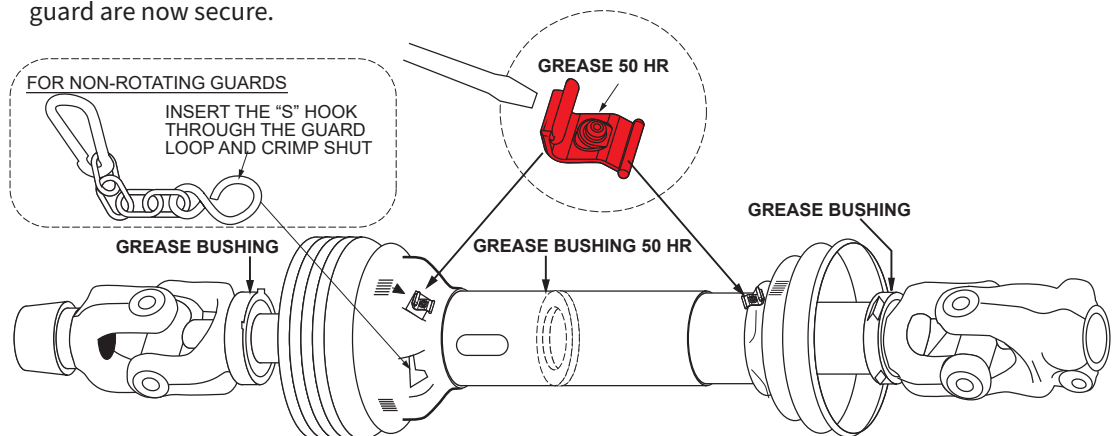

#### TOOLS REQUIRED:

Screwdriver, High Quality Multi-Purpose Grease, Pliers

#### IMPORTANT:

Check that guard missing decal on steel tube under inner guard and rotating drive shaft decal on outer guard are firmly affixed, undamaged and readable—if not, replace.

