

80° CONSTANT VELOCITY UNIVERSAL JOINT

Weasler®

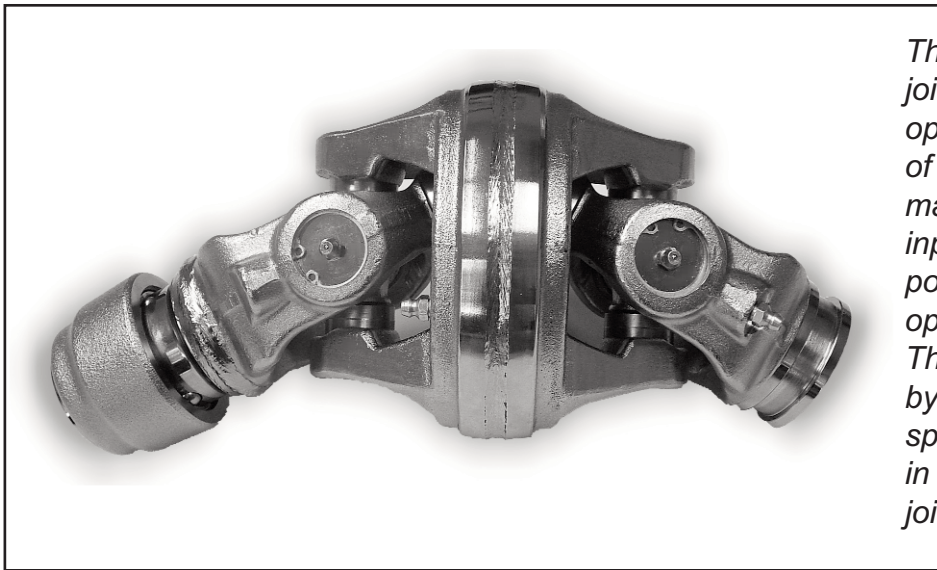

The constant velocity universal joint (CV) allows smooth machine operation through a broad range of motion. These joints allow the machine to be designed with the input shaft in the best operating position and yet allow the operator to maneuver as needed. The CV delivers constant power by self-canceling torque and speed fluctuations typically found in single cardan-type universal joints.

PERFORMANCE BENEFITS

- SIZES AVAILABLE FROM 15 HP TO 232 HP (12 kW TO 173 kW) FOR 1000 HOURS OF LIFE AT 10° TOTAL ANGLE
- MINIMAL VIBRATION AT HIGH TURN ANGLES
- LIGHT WEIGHT COMPACT DESIGN FOR HANDLING EASE
- FLOATING PLATES SEAL IN LUBRICATION AND SEAL OUT CONTAMINATION
- HARDENED SPHERICAL BALL AND SOCKET PROVIDES LONG LIFE
- NUMEROUS TELESCOPING MEMBERS TO MEET APPLICATION REQUIREMENTS
- AUTO-LOK YOKES AVAILABLE FOR EASE OF ATTACHMENT
- ARTICULATED GUARD SYSTEM PROVIDES FULL COVERAGE AT MAXIMUM ANGLE
- CAN BE LUBRICATED WITH THE GUARD SYSTEM IN POSITION
- GUARD SYSTEMS MEET ALL INTERNATIONAL STANDARDS
- "E" CROSS AND BEARING KIT AVAILABLE FOR INCREASED DYNAMIC CAPACITY
- EXTENDED LUBRICATION DESIGN AVAILABLE FOR REDUCED MAINTENANCE

80° CONSTANT VELOCITY UNIVERSAL JOINT

Weasler®

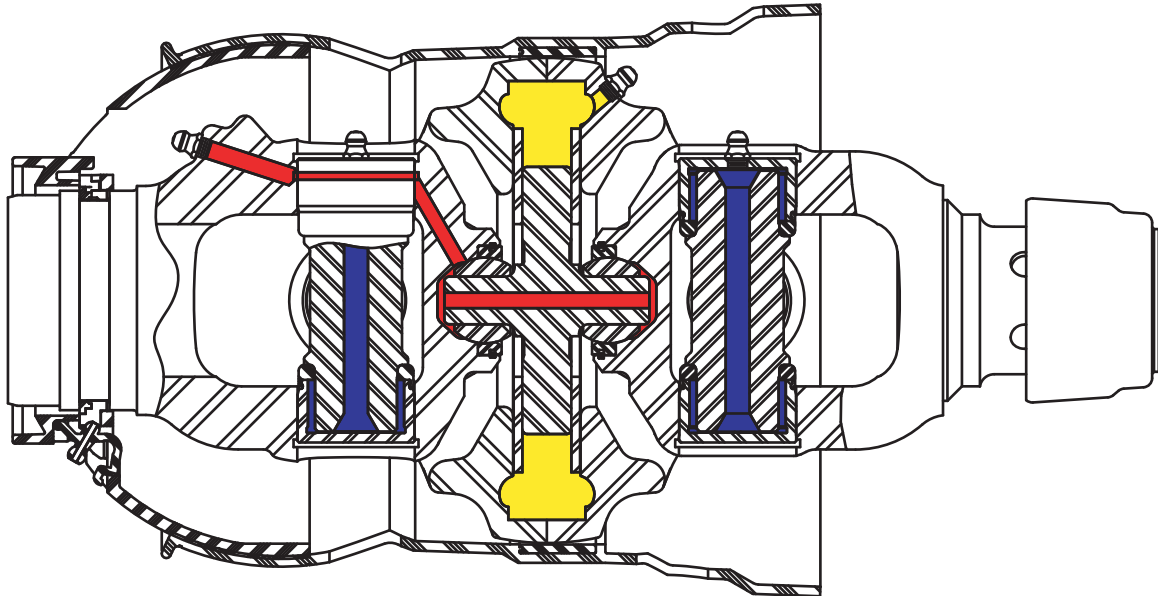

DESIGN FEATURES

- 80° MAXIMUM SHORT DURATION OR STANDSTILL OPERATION
WARNING: OPERATING BEYOND 80° WILL RESULT IN JOINT DAMAGE
- 25° MAXIMUM CONTINUOUS OPERATION
NOTE: OPERATING CONDITIONS MUST BE REVIEWED BY WEASLER APPLICATIONS ENGINEERING.
- SINGLE POINT PRESSURIZED BALL AND SOCKET LUBRICATION SYSTEM (PATENTED)
- HARDENED BALL AND SOCKET (PATENTED)
- CENTERING DEVICE INCLUDES FLOATING PLATES (PATENTED)
- MOST COMPACT POWER TO SIZE RATIO IN THE INDUSTRY
- INTEGRAL BRIDGE YOKES
- TELESCOPING MEMBERS:
 - HARDENED SPLINE OR RECTANGULAR SHAFTING
 - STANDARD COATED PROFILE TUBE SIZES
- AUTO-LOK ATTACHMENT AVAILABLE
- CE CERTIFIED AND ISO COMPLIANT ARTICULATED GUARD SYSTEMS (PATENTED)
- OPERATING TORQUE UP TO 24,000 in•lb, 2712 Nm
- "E" CROSS AND BEARING KIT AVAILABLE FOR INCREASED DYNAMIC CAPACITY
- EXTENDED LUBRICATION SYSTEM AVAILABLE:
 - "E" CROSS AND BEARING KITS
 - SEALED BALL AND SOCKET SYSTEM (PATENTED)
 - SEALED CENTER HOUSING (PATENTED)